

# Harnessing the Power of Electroconductive Polymers for Breakthroughs in Tissue Engineering and Regenerative Medicine

Mahsa Ghovvati<sup>1\*</sup>, Keivan Bolouri<sup>1</sup>, Lea Guo<sup>1</sup>, Naoki Kaneko<sup>1</sup>, Xuru Jin<sup>2</sup>, Yi Xu<sup>3</sup>, Zhidan Hua<sup>2</sup>, Ying Lei<sup>2</sup>

<sup>1</sup>Department of Radiological Sciences, David Geffen School of Medicine, University of California – Los Angeles, Los Angeles, CA 90095, USA

<sup>2</sup>Department of Respiratory and Critical Care Medicine, NanoBioMedical Group, The Quzhou Affiliated Hospital of Wenzhou Medical University, Quzhou People's Hospital, Quzhou, China

<sup>3</sup>Department of Science & Technology, Department of Urology, Nano Medical Innovation & Collaboration Group (NMICG), The Quzhou Affiliated Hospital of Wenzhou Medical University, Quzhou People's Hospital, Quzhou, China

\*Corresponding authors: [MGhovvati@mednet.ucla.edu](mailto:MGhovvati@mednet.ucla.edu) (M. Ghovvati)



Mater. Chem. Horizons, 2023, X, XX-XX



10.22128/mch.2023.693.1042



## ABSTRACT

Electroconductive polymers (ECPs) have garnered increasing attention in the realms of tissue engineering and regenerative medicine due to their unique physicochemical properties, including their ability to conduct electrical signals. These polymers, with inherent conductivity mirroring that of native tissues, present a promising platform for scaffolds that can modulate cell behavior and tissue formation through electrical stimulation. The biocompatibility, tunable conductivity, and topographical features of ECPs enhance cellular adhesion, proliferation, and differentiation. Furthermore, their electrical properties have been shown to augment nerve regeneration, cardiac tissue repair, and musculoskeletal tissue formation. Combined with other biomaterials or biological molecules, ECP-based composites exhibit synergistic effects, promoting enhanced tissue regeneration. Moreover, the integration of ECPs with cutting-edge technologies such as 3D printing and microfluidics propels the design of sophisticated constructs for tissue engineering applications. This paper concludes with the challenges faced in the clinical translation of ECP-based scaffolds and provides perspectives on the future trajectory of ECPs in regenerative medicine. The synthesis of ECPs with emerging biotechnologies has the potential to revolutionize treatments, bridging the gap between traditional regenerative approaches and sophisticated bioelectronic remedies.

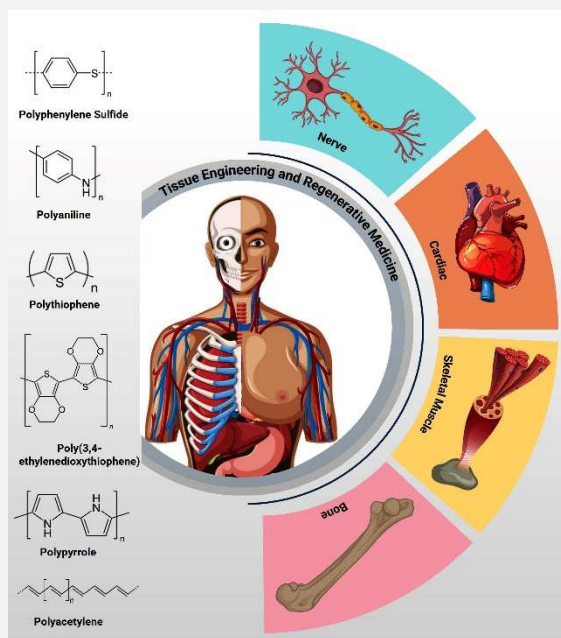

**Keywords:** Electroconductive polymers, tissue engineering, regenerative medicine, biomedical applications

## 1. Introduction

Tissue engineering and regenerative medicine represent the most exciting field in current biomedical research. Their goal, often intertwined, is to restore, maintain, or enhance the functionality of damaged or lost tissues and organs. These highly interdisciplinary domains bring together principles from biology, chemistry, physics, and engineering to develop innovative solutions to address some of today's most critical healthcare issues [1, 2].

A key element of both tissue engineering and regenerative medicine is the utilization of suitable biomaterials to support the growth, differentiation, and function of cells. These materials often need to replicate the intricate, dynamic nature of native tissue environments to effectively guide cellular processes, which is a challenging task. In recent decades, electroconductive polymers (ECPs) have garnered substantial interest in this regard [3, 4]. ECPs diverge considerably from traditional polymers due to their ability to conduct electricity. This property results from the

Received: June 20, 2023  
Revised: August 21, 2023  
Accepted: August 22, 2023



delocalization of  $\pi$  electrons along the polymer backbone, allowing them to behave more like metals or semiconductors than typical insulating polymers. Applications for these materials span across numerous domains, from flexible electronics and batteries to sensors and biomedical devices. Their significance in tissue engineering and regenerative medicine is particularly profound because many tissues, such as nerve, cardiac, skeletal muscle, and bone, depend on electrical signaling for their normal function [4-7].

Herein, we will delve into the underlying principles and properties of ECPs. Subsequently, we will discuss their application in tissue engineering and regenerative medicine. We will also provide an outlook on the future prospects of ECPs in this field, emphasizing areas where we anticipate the most significant advances.

## 2. Electroconductive polymers (ECPs)

In the late 1970s, Alan J. Heeger, Alan G. MacDiarmid, and Hideki Shirakawa made a revolutionary discovery related to the conductivity of polymers. Prior to their research, polymers were typically viewed as insulators. However, these scientists demonstrated that polyacetylene (PA), a simple polymer based on the alkene group, could have its conductivity enhanced when doped with iodine. The doped polymer took on properties similar to metals, a finding that was truly groundbreaking. It challenged and expanded the conventional understanding of materials and blurred the lines between what were once thought to be distinct categories: insulating polymers and conductive metals. In acknowledgment of their monumental contribution to the field of chemistry, and by extension to materials science and electronics, they were awarded the Nobel Prize in Chemistry in the year 2000. Their discovery laid the foundation for various applications of conductive polymers, including their use in organic electronic devices, sensors, and more [8].

In the decades following this discovery, a wave of new ECPs, such as polyaniline (PANI), polypyrrole (PPy), and polythiophene (PT), were discovered and synthesized. These polymers cleverly combined the advantages of plastics, such as mechanical resilience and easy processability, with the electronic and optical properties typical of metals and semiconductors. This paved the way for their use in a wide variety of applications, spanning from flexible electronics to solar cells, and more recently, to biomedical applications [7, 9].

The unique electrical conductivity of ECPs is a product of their molecular structure. They are characterized by a series of alternating single and double bonds along the polymer backbone, forming a conjugated system (**Figure 1**). This conjugation allows  $\pi$  electrons, which are associated with the double bonds, to become delocalized, effectively enabling them to move freely along the length of the polymer chain, and hence conferring electrical conductivity [4, 10, 11]. Although, in their pristine state, these polymers are typically not highly conductive, their conductivity can be significantly boosted through a process known as doping. Doping involves the intentional introduction of impurities, which can either act as electron acceptors (p-type doping) or electron donors (n-type doping). These dopants interact with the conjugated system, either removing an electron (p-type doping) or supplying an electron (n-type doping) to it. This process generates mobile charge carriers within the polymer, dramatically increasing its ability to conduct electricity [12-15].

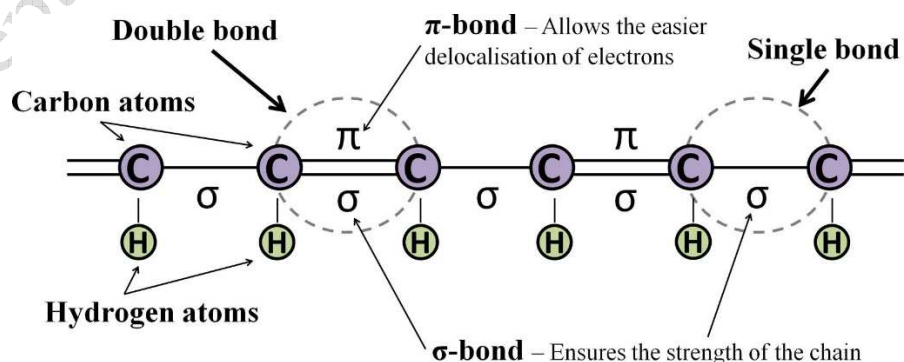

**Figure 1.** A basic diagram representing a conjugated backbone, which is a chain composed of alternating single and double bonds. Reproduced with permission from [4] Copyright 2014, Elsevier

Among the broad class of ECPs, a few of them have garnered particular attention due to their exceptional electronic properties, processability, and stability. For instance, PANI stands as one of the most extensively studied ECPs, primarily due to its high electrical conductivity, cost-effectiveness, low toxicity, low operational voltage, good chemical and thermal stability, and ease of synthesis. Intriguingly, it can exist in several oxidation states, each corresponding to a different level of conductivity, thereby providing a range of tunable electronic properties [16-20]. PPy, characterized by its excellent conductivity and straightforward polymerization process, has also found extensive use in the realm of biomedicine. Its inherent biocompatibility makes it an ideal candidate for biological and medical applications, from drug delivery systems to tissue engineering scaffolds [21, 22]. Another example of commonly used ECPs is PT. PT and its derivatives occupy a crucial space in the world of organic electronics. Their popularity arises from their high conductivity, excellent environmental and thermal stability, and reduced band gap energy [19, 23].

The capability of these ECPs to modulate cellular behavior through electrical stimulation offers a realm of opportunities in tissue regeneration. Moreover, the compatibility of these polymers with various biotechnologies, such as 3D printing and microfluidics, amplifies their potential in designing intricate tissue constructs that mirror native tissue dynamics.

### 3. Versatile properties of ECPs in biomedical applications

#### 3.1. Antimicrobial activity

Infections caused by microorganisms like bacteria pose a significant threat to human health, and effective treatment is crucial [24]. However, with the last new antibiotic class being introduced in 2003, treating many infectious diseases has become increasingly challenging, particularly those caused by multidrug-resistant bacteria [25]. The post-antibiotic era, where previously responsive infections become resistant to even the most antibiotics, has led to a need for new strategies to fight microbial infections [26]. The Centers for Disease Control and Prevention in the US estimated that over 2 million infections and close to 23,000 deaths per annum were caused globally by antibiotic-resistant ESKAPE pathogens, including *Staphylococcus aureus*, *Klebsiella pneumoniae*, and *Enterobacter* species [27].

In combating these extensively drug-resistant pathogens, antimicrobial materials offer a promising microbial strategy [28]. Biomedical devices containing antimicrobial composites have received significant attention in both academia and the pharmaceutical industry [29]. These materials can be classified into those that are intrinsically antimicrobial, those that act as carriers for antimicrobial agents, and those that possess both functional properties.

One example of intrinsically antimicrobial materials is antimicrobial PANI composites [30, 31]. PANI has been applied in biomedicine, including electrotherapy, antimicrobial clothing, and electromagnetic devices for health monitoring [20]. PANI composites have been developed in combination with various antimicrobial agents, including silver nanoparticles, titanium oxides, and non-leachable compounds such as quaternary ammonium salts, to prepare a number of antimicrobial devices [32]. These devices show significant potential for use in biomedical applications to combat infections caused by multidrug-resistant bacteria. PANI-based compounds have been synthesized to control microbial contaminations, and their antimicrobial activity has been reported against both Gram-negative and Gram-positive bacteria [33]. Various nanomaterials, polymers, and other compounds have been added to PANI to enhance its antimicrobial activity, conductivity, and photocatalytic activity. For example, PANI-based composites consisting of different nanoarchitectures such as rods, spherical particles, tubes, and sheets have been developed and have shown promising results in biomedical applications [34].

PPy is another ECP that has been extensively studied for its antimicrobial properties. PPy exhibits excellent biocompatibility and has shown antimicrobial activity against a broad spectrum of microorganisms, including bacteria, fungi, and viruses [35-37]. PPy-based antimicrobial coatings have been developed for various biomedical applications, such as orthopedic implants, wound dressings, and catheters [37]. These coatings can prevent biofilm formation and bacterial adhesion, which are common causes of implant-associated infections. In addition, PPy nanoparticles have been shown to have potential for use as an antimicrobial agent in various drug delivery systems [38]. The antimicrobial mechanism of PPy is not well understood, but it is believed to involve the disruption of the bacterial membrane and the generation of reactive oxygen species (ROS). PPy can also interact with the bacterial DNA, resulting in the inhibition of bacterial growth [39]. Overall, PPy is a promising material for the development of antimicrobial coatings

and drug delivery systems due to its biocompatibility, easy synthesis, and broad-spectrum antimicrobial activity. However, further research is needed to fully understand its antimicrobial mechanism and optimize its properties for specific biomedical applications.

### 3.2. Antioxidant activity

ECPs exhibit antioxidant activity, which means they have the ability to neutralize free radicals such as ROS, hydroxyl radicals,  $H_2O_2$ , superoxide anion radicals, and reactive nitrogen species by donating electrons or active hydrogen atoms [40]. Free radicals are not only produced in food samples (through lipid oxidation) and can affect food quality, but they are also generated in cells through intracellular metabolism and are eliminated by intracellular antioxidant mechanisms to maintain homeostasis between intracellular oxidation and antioxidant effects [41]. However, if this balance is disrupted, a condition known as oxidative stress can occur, leading to cell damage and creating a favorable environment for the development of neurodegenerative disorders, various types of cancers, and cardiovascular diseases [42].

Antioxidants are essential due to the harmful effects of free radicals, such as tissue damage and the progression of diseases like inflammation, heart disease, cancer, and premature aging [43]. Antioxidants, as their name suggests, are substances that prevent the oxidation of other molecules. They play a crucial role in protecting both food and body tissues and reducing the risk of chronic diseases, thereby contributing to overall human health [44].

ECPs has shown promise in reducing the overexpression of reactive radical species and may be effective in treating tissues experiencing oxidative stress [45]. The antioxidant activity of ECPs can be assessed easily by their reaction with 1,1-diphenyl-2-picrylhydrazyl (DPPH), a free radical molecule, as a scavenger. This interaction involves the transfer of electrons and hydrogen from the polymers to DPPH to neutralize the scavenger. The resulting quenching of free radicals occurs in the microenvironment, causing a noticeable color change. Consequently, ECPs may provide a beneficial antioxidant effect to damaged tissues [46].

ECPs can be oxidized to generate positively charged centers on the polymer backbone, which can be balanced by the anionic form of DPPH or soluble anions, or DPPH may remove a proton from the polymer to form DPPH. The fact that several DPPH radicals are scavenged for each unit of aniline or pyrrole in ECPs suggests that additional reaction pathways may be involved in which the polymer distributes the charge into the surrounding solution [46]. PPy has been identified as a potent antioxidant that can counteract a variety of free radical species by donating electrons or active hydrogen atoms to the radicals, thereby preventing oxidative damage caused by free radicals [47].

### 3.3. Biocompatibility

Biocompatibility is an important consideration when developing materials for biomedical applications, including ECPs [48]. Cytotoxicity concerns are gaining attention as the intentional interaction of materials with cells has the potential to create adverse effects in the human body. Therefore, it is crucial to ensure that the materials used do not harm the body [49].

PPy and its composites have been used extensively in biomedical applications. It is important to identify the factors that affect their biocompatibility to evaluate their use in clinical trials. For instance, the half maximal inhibitory concentration (IC50) of PPy, which is a measure of its potency in inhibiting a specific biological function, is 0.77 mM [50]. This value indicates that PPy is partially cytotoxic, and the toxicity of PPy composites on normal cells is concentration-dependent.

Coating or surface modification of PPy with natural products can improve its biocompatibility [7]. Natural polymers such as chitosan, hyaluronic acid, and gelatin have been applied to enhance the safety profile of nanomaterials. For example, when dextran was used as a shell for PPy-based nano-assemblies, its biocompatibility was improved [51].

PANI and its composites are being investigated as promising materials for biomedical applications. As with other materials, the biocompatibility and cytotoxicity of PANI and its composites are important considerations for their use in medical applications [52]. Biocompatibility refers to the ability of a material to coexist with living tissue without causing harm, while cytotoxicity refers to the toxic effects of the material on cells. The structures of PANI and its composites can affect both biocompatibility and cytotoxicity [53].

Studies have shown that the deprotonation-reprotonation cycles undertaken by PANI can decrease its cytotoxicity, but it is not expected to be toxic because it is insoluble and stable in aqueous solutions [54]. Low molecular weight compounds that result from byproducts with oligomers of aniline or from the acids that form PANI salts are the primary sources of cytotoxicity. The modification of PANI can significantly improve its biocompatibility and reduce cytotoxicity [55]. PANI has been found to be biocompatible in terms of dermal irritation and sensitization according to ISO 10993 standards [54]. Additionally, PANI composites have shown outstanding biocompatibility properties in the duration of dermal irritation [56].

Researchers have investigated the biocompatibility of PANI using various cell lines, including mouse embryonic fibroblast (NIH/3T3) cell lines and embryonic stem cells [57]. The results have shown that the correlation of cytotoxicity with impurity contents is not always strictly linear. Studies have found that PANI salts and PANI-based compounds have similar cytotoxicity levels [53]. However, further studies are necessary to better understand the biocompatibility and cytotoxicity of PANI and its composites for various medical applications.

#### 4. ECPs in tissue engineering and regenerative medicine

Tissue engineering and regenerative medicine are interdisciplinary fields that aim to regenerate, repair, replace, or enhance the function of damaged or diseased tissues and organs. This is typically accomplished by combining cells with three-dimensional scaffolds that mimic the extracellular matrix, providing a supportive environment for cells to grow and differentiate [58]. Through conductive scaffolds, the normal bioelectric flow in the body could be linked, thereby enhancing tissue regeneration. Furthermore, external electrical stimulation can modulate cellular functions such as cell migration, DNA synthesis, and protein secretion [59].

ECPs have emerged as a promising class of materials for the design of advanced tissue engineering scaffolds. ECPs can be engineered to deliver electrical and biological cues that stimulate the body's own repair mechanisms. For instance, electrical stimulation through conductive scaffolds can enhance cell migration and proliferation, aiding in wound healing and tissue repair [56, 60, 61]. For cell therapies and organ transplants, ECPs can be used to engineer highly functional, patient-specific tissues in the lab. They can enhance cell maturation and tissue formation, leading to improved graft survival and integration post-transplantation [4, 62]. Moreover, ECPs can be used to design smart drug delivery systems that respond to electrical signals, allowing for controlled and targeted release of therapeutic agents. Such systems can improve treatment efficacy and minimize side effects [11, 63]. ECPs have seen innovative use in the design of bioelectrodes for neuromodulation therapies, as biosensors for real-time monitoring of physiological signals, and as components of microdevices for minimally invasive therapies. Additionally, the advent of advanced fabrication techniques like 3D bioprinting has allowed for the creation of complex, patient-specific tissue constructs using ECPs. By integrating the electrical properties of ECPs with the strength, stability, and functionality of other polymers/biomaterials, these composites can simulate the electrical microenvironment of native tissues, particularly those that are electroactive like neural, muscular, and cardiac tissues [11, 64, 65].

**Table 1** presents the electrical conductivity values for various native tissues sourced from *in vivo* animal models, mostly from rats. As indicated in this table, to effectively engineer different tissues, it's imperative for researchers to consider these values, ensuring their engineered electroconductive scaffolds align with these electrical characteristics. However, these values are not absolute and different measurement systems and various factors can result in slight variations in the values obtained by different researchers [66].

**Table 1.** The range of electrical conductivity values for different native tissues [66].

Tissue	Nerve	Cardiac	Skeletal muscle	Bone	Lung	Liver
Electrical conductivity, S/m	0.08–1.3	0.005–0.16	0.04–0.5	0.02–0.06	0.04–0.2	0.05–1

In neural tissue engineering, ECPs can play a crucial role in promoting neurite outgrowth and enhancing neural signal transmission. These materials have shown potential in supporting the growth and differentiation of neural stem cells, aiding in nerve injury repair and the treatment of neurodegenerative diseases [7, 64, 67, 68]. Moreover, the heart's electroactive nature makes ECPs an attractive option for cardiac tissue engineering. These materials can

enhance the maturation and electrophysiological functionality of cardiomyocytes, driving the formation of functional cardiac tissues for heart repair [4, 11, 64, 69, 70]. For musculoskeletal tissues, including bone, cartilage, and muscle, ECPs can support cell attachment, proliferation, and differentiation. For instance, these materials can guide osteogenic differentiation of stem cells, promoting bone regeneration [11, 71-75]. **Table 2** provides some examples of ECPs utilized in nerve, cardiac, skeletal muscles, and bone tissue engineering. The scaffolds used in these studies, such as hydrogels, electrospun nanofibrous scaffolds, 3D printed constructs, and nanostructured films and membranes were used as a replacement for native tissue's extracellular matrix, which provides an appropriate substrate for tissue mechanical integrity while facilitating cell adhesion, proliferation, and differentiation.

Numerous innovations have been made in the design and application of ECPs for tissue engineering. These include the development of composites with tailored conductivity, mechanical properties, and bioactive cues; the fabrication of complex 3D scaffold structures using techniques like 3D printing; and the design of electrically responsive systems for on-demand delivery of growth factors or genes. These advancements demonstrate the potential of ECPs in creating more sophisticated and effective tissue engineering strategies. Nevertheless, several challenges persist, such as ensuring optimal biocompatibility, adjusting degradation rates, managing the controlled release of bioactive molecules, and maneuvering through the regulatory framework for clinical application. Despite these hurdles, the progress in this field paints a promising picture for the future of tissue engineering and regenerative medicine [11, 76, 77].

While promising, the use of ECPs in regenerative medicine also faces challenges, such as ensuring long-term stability and performance in the physiological environment, understanding the *in vivo* response to these materials, and meeting regulatory requirements for safety and efficacy. However, continued research and technological advancements hold the promise of overcoming these challenges and realizing the full potential of ECPs in regenerative medicine [4, 11, 60].

**Table 2.** Examples of ECPs employed in tissue engineering.

Tissue	ECP	Composite	Cell type	Animal model	Outcome	Ref
Nerve	PPy	PPy/PCL	hESC-NCSCs	N/A	hESC-NCSCs differentiation to peripheral neurons on the scaffolds	[59]
		PPy/Chitosan	Schwann cells	N/A	Cell adhesion, spreading, and proliferation on the membranes	[78]
	PEDOT	PEDOT NPs/SF	BJ fibroblast cells/Schwann cells	N/A	Prevention of scar tissue formation in the lumen with no toxicity	[79]
		PEDOT NPs/Chitin/CRGD	Schwann cells	Sciatic nerve defect rat model	Attachment and proliferation enhancement of Schwann cells and angiogenesis	[67]
Cardiac	PANI	PANI/PLA	H9c2 cardiomyoblast/RNCMs	N/A	Promoting effect on differentiation of H9c2 cardiomyoblasts in terms of maturation index and fusion index; Improvement of the cell-cell interaction, maturation and spontaneous beating of primary CMs	[80]
		PANI/PGS	C2C12 cells	N/A	Improvement of electrical conductivity	[81]
	PPy	PPy/SF	Primary RNCMs/hiPSC-CMs	N/A	Elongation and anisotropically orientation of primary RNCMs on PPy/SF with locally organized sarcomeric striations; Strong contractions of hiPSC-CMs on PPy/SF	[82]

		PPy NPs/ GelMA/PEGDA	RNCMs	MI rat models	Functionalization enhancement of the CMs; Excellent synchronous contraction by increasing the expression of $\alpha$ -actinin and connexin-43; Improvement of the cardiac function <i>in vivo</i>	[69]
		PPy/PCL	HL-1 atrial myocytes	N/A	Improvement of formation of connexin-43 to enhance cell-cell communication, resulting in higher velocities for calcium wave propagation, and reducing calcium transient duration	[83]
		PPy NPs/BC	cardiac fibroblasts/ H9c2	N/A	Increase in the expression of functional cardiac markers in H9c2 cells	[84]
Skeletal Muscle	PANI	PANI/ Chitosan/Dextran	Mouse C2C12 myoblast/AdMS Cs	N/A	Promotion of cell proliferation on the scaffolds	[85]
		PANI/PAN	hMSCs	N/A	Support of cell growth; promote hMSCs differentiation into muscle-like cells (gene expression and immunocytochemistry)	[86]
		PANI/PCL	Mouse C2C12 myoblast	N/A	Promotion of cell growth, orientation and myotube formation	[87]
		PANI/Gelatin	Mouse C2C12 myoblast	N/A	Enhancement of myogenesis, myotube maturation	[88]
		PANI/PCL/SF	Mouse C2C12 myoblast	N/A	Promotion of cell growth, elongation and myotube formation	[89]
		PANI/PAN	Mouse satellite cells	N/A	Promote differentiation	[90]
		PANI/PAN/CSA/G	Mouse satellite cells	N/A	Promote proliferation and differentiation	[91]
		PPy	PPy/GG/SLH	Mouse C2C12 myoblast	N/A	Support of cell adhesion and spreading
	PEDOT	PEDOT/PU	NG108-15 neuron cells/Mouse C2C12 myoblast	N/A	Support of cell adhesion and spreading	[93]
		PEDOT NPs/PCL	Rat muscle cells	N/A	Good cytocompatibility	[94]
Bone	PANI	PANI/PCL	AdSCs	N/A	Exhibition of suitable conductivity for bone tissue engineering applications and cytocompatibility	[95]
		PANI-TiO <sub>2</sub> NPs/PCL	MC3T3-E1 cells	N/A	Formation of hydroxyapatite layer on the surface of the nanofibrous webs in SBF	[96]
		PANI/TNTs	MC3T3-E1 cells	N/A	Enhancement in proliferation of pre-osteoblast cells	[55]
		PDA-modified PVA/PU-PANI	Rat BMSCs	N/A	Support of the formation of hydroxyapatite- like crystals; Higher expression of alkaline phosphatase and secretion of Collagen I under the electrical field indicating the applicability of modified electroconductive scaffolds as a reconstructive bone substitute	[97]

	PEDOT/Fe <sub>3</sub> O <sub>4</sub> /PLGA	MC3T3-E1 cells	N/A	Improve in cell proliferation; Induce cell alignment arrangement.	[98]
PEDOT	PEDOT:PSS/Gelatin/BG	DPSCs	Rabbit skull defect model	Enhancement in cell; New bone formation <i>in vivo</i>	[75]
PPy	PPy NPs/PCL	MC3T3-E1 cell	N/A	Increase in SBF-biomineralization; Enhancement of MC3T3-E1 cell adhesion, proliferation, and differentiation in electrical stimulation conditions	[99]

**Abbreviations:** AdMSCs: adipose-derived mesenchymal stem cells; AdSCs: adipose-derived stem cells; BC: Bacterial nanocellulose; BG: Bioactive glass; BMSCs: Bone marrow mesenchymal stem cells; CMs: Cardiomyocytes; CRGD: Cell adhesive tetrapeptide Cys–Arg–Gly–Asp; CSA: Camphor sulfuric acid; DPSCs: Dental pulp stem cells; ECP: Electroconductive polymers; Fe<sub>3</sub>O<sub>4</sub>: Iron oxide; G: Graphene; GelMA: Gelatin methacryloyl; GG: Gellan gum; hESC-NCSCs: Human embryonic stem cell-derived neural crest stem cells; hiPSC-CMs: Human induced pluripotent stem cell-derived cardiomyocytes; hMSCs: Human mesenchymal stem cells; MI: Myocardial infarction; NPs: Nanoparticles; PAN: Polyacrylonitrile; PANI: Polyaniline; PCL: Poly( $\epsilon$ -caprolactone); PDA: Polydopamine; PEDOT: Poly(3,4-ethylenedioxythiophene); PEGDA: Poly(ethylene glycol)diacrylate; PGS: Poly(glycerol-sebacate); PLA: Poly(L-lactic acid); PLGA: Polylactic-co-glycolic acid; PPy: Polypyrrole; PSS: Poly(4-styrene sulfonate); PU: Polyurethane; PVA: Polyvinyl alcohol; RNCMs: Rat neonatal cardiomyocytes; SBF: Simulated body fluid; SF: Silk fibroin; SLH: Spongy-like hydrogels; TNTs: Titanium oxide nanotubes

## 5. Challenges and future perspectives

While the potential of ECP composites in tissue engineering and regenerative medicine is clear, several challenges remain that need to be addressed. For instance, ensuring the biocompatibility of these materials is critical, as any adverse immune or inflammatory responses could compromise their performance and safety. In addition, controlling the biodegradability of these materials to match the tissue regeneration rate is a complex task that requires further research [7, 72]. Moreover, there is a substantial gap between laboratory research and clinical applications. The scalability, reproducibility, and cost-effectiveness of producing the ECP composites are issues that need to be resolved. Furthermore, these materials must meet strict regulatory requirements regarding their safety and efficacy before any clinical use [4, 72].

Despite these challenges, the field of ECPs is rich with opportunities, and continued research and innovation in this area are expected to drive significant advancements in tissue engineering and regenerative medicine including (i) Advanced Material Design: Future research will likely focus on the design of novel ECPs with enhanced electrical, mechanical, and biological properties. For instance, incorporating bioactive molecules within these materials can provide additional functionality, (ii) Innovative Fabrication Techniques: The development of new fabrication techniques, such as advanced 3D printing technologies, could enable the creation of more complex and patient-specific structures, offering significant improvements in the treatment of a variety of medical conditions; (iii) Integrated Systems: Looking forward, there is an exciting potential for the development of integrated systems that combine ECPs with other technologies, such as microelectronics, optogenetics, and wireless technology. Such integrated systems could offer unprecedented control over tissue regeneration and repair processes.

In conclusion, while significant challenges remain, the future of ECPs in tissue engineering and regenerative medicine is promising. As we continue to expand our understanding of these materials and develop new ways to manipulate their properties, they will undoubtedly play a central role in the evolution of next-generation of biomedical treatments.

## 6. Conclusion

The advent of ECPs has ushered in a new era in the fields of tissue engineering and regenerative medicine. By leveraging the beneficial properties of these unique materials, researchers have unlocked unprecedented opportunities to tackle some of the most complex medical challenges, ranging from the treatment of neurodegenerative diseases to cardiac repair and bone regeneration.



A significant advantage of ECPs is their ability to mimic the natural electrical microenvironment of various tissues. Despite the promising progress and the multitude of applications demonstrated so far, a clear understanding of the challenges, including issues related to biocompatibility, biodegradability, fabrication techniques, and regulatory hurdles, is crucial. The successful clinical translation of these ECPs can only be achieved through concerted efforts to address these challenges. Peering into the future, the adaptability of ECPs, combined with ongoing advancements in material creation and manufacturing methods, suggests a bright horizon for their expanded use in tissue engineering and regenerative medicine. It is anticipated that ongoing research in this vibrant field will yield more sophisticated systems, capable of treating a broad spectrum of health conditions, thereby improving the quality of life for patients around the globe. In conclusion, although the exploration of ECPs' full potential continues, the advancements so far underscore their significant potential to revolutionize tissue engineering and regenerative medicine. The ongoing synergy between materials science and biology is expected to inspire a plethora of innovative solutions in the forthcoming years.

### Conflict of interest

The authors declare no conflict of interest

### References

- [1] F. Han, J. Wang, L. Ding, Y. Hu, W. Li, Z. Yuan, Q. Guo, C. Zhu, L. Yu, H. Wang, Z. Zhao, L. Jia, J. Li, Y. Yu, W. Zhang, G. Chu, S. Chen, B. Li, *Tissue Engineering and Regenerative Medicine: Achievements, Future, and Sustainability in Asia*, *Front. Bioeng. Biotechnol.* 8 (2020) 83.S.F. Badylak, R.M. Nerem, *Progress in tissue engineering and regenerative medicine*, *PNAS* 107 (2010) 3285-3286.
- [2] S.G. Alamdari, A. Alibakhshi, M. de la Guardia, B. Baradaran, R. Mohammadzadeh, M. Amini, P. Kesharwani, A. Mokhtarzadeh, F. Oroojalian, A. Sahebkar, *Conductive and Semiconductive Nanocomposite-Based Hydrogels for Cardiac Tissue Engineering*, *Adv. Healthc. Mater.* 11 (2022) e2200526.
- [3] R. Balint, N.J. Cassidy, S.H. Cartmell, *Conductive polymers: Towards a smart biomaterial for tissue engineering*, *Acta Biomater.* 10 (2014) 2341-2353.
- [4] L. Ghasemi-Mobarakeh, M.P. Prabhakaran, M. Morshed, M.H. Nasr-Esfahani, H. Baharvand, S. Kiani, S.S. Al-Deyab, S. Ramakrishna, *Application of conductive polymers, scaffolds and electrical stimulation for nerve tissue engineering*, *J. Tissue Eng. Regen. Med.* 5 (2011) e17-35.
- [5] M.A. Khan, E. Cantù, S. Tonello, M. Serpelloni, N.F. Lopomo, E. Sardini, *A Review on Biomaterials for 3D Conductive Scaffolds for Stimulating and Monitoring Cellular Activities*, *Appl. Sci.* 9 (2019) 961.
- [6] B. Guo, P.X. Ma, *Conducting Polymers for Tissue Engineering*, *Biomacromol.* 19 (2018) 1764-1782.
- [7] A.J. Heeger, A.G. MacDiarmid, H. Shirakawa, Alan J. Heeger, Alan G. MacDiarmid, and Hideki Shirakawa, *Macromol.* 35 (2002) 1137-1139.
- [8] A.-D. Bendrea, L. Cianga, I. Cianga, *Review paper: Progress in the Field of Conducting Polymers for Tissue Engineering Applications*, *J. Biomater. Appl.* 26 (2011) 3-84.
- [9] D.D. Ateh, H.A. Navsaria, P. Vadgama, *Polypyrrole-based conducting polymers and interactions with biological tissues*, *J. R. Soc. Interface.* 3 (2006) 741-752.
- [10] Ö. Lalegül-Ülker, A.E. Elçin, Y.M. Elçin, *Intrinsically Conductive Polymer Nanocomposites for Cellular Applications*, in: H.J. Chun, C.H. Park, I.K. Kwon, G. Khang (Eds.), *Cutting-Edge Enabling Technologies for Regenerative Medicine*, Springer Singapore, Singapore, 2018, pp. 135-153.
- [11] A.G. MacDiarmid, R.J. Mammone, R.B. Kaner, L. Porter, R. Pethig, A.J. Heeger, D.R. Rosseinsky, R.J. Gillespie, P. Day, *The concept of 'doping' of conducting polymers: the role of reduction potentials*, *Philosophical Transactions of the Royal Society of London. Series A, Math. Phys. Sci.* 314 (1985) 3-15.
- [12] R. Kroon, A.I. Hofmann, L. Yu, A. Lund, C. Müller, *Thermally Activated in Situ Doping Enables Solid-State Processing of Conducting Polymers*, *Chem. Mater.* 31 (2019) 2770-2777.
- [13] N. K. C.S. Rout, *Conducting polymers: a comprehensive review on recent advances in synthesis, properties and applications*, *RSC Adv.* 11 (2021) 5659-5697.
- [14] I.-R. Jeon, N. Noma, R.F.C. Claridge, Y. Shirota, *Electrochemical Doping of Poly(3-vinylperylene) and Electrical Properties of Doped Polymers*, *Polym. J.* 24 (1992) 273-279.
- [15] S. Bhadra, D. Khastgir, N.K. Singha, J.H. Lee, *Progress in preparation, processing and applications of polyaniline*, *Prog. Polym. Sci.* 34 (2009) 783-810.

- [16] A.A. Syed, M.K. Dinesan, Polyaniline—A novel polymeric material, *Talanta* 38 (1991) 815-837.
- [17] Z.A. Boeva, V.G. Sergeev, Polyaniline: Synthesis, properties, and application, *Polym. Sci. Ser. C* 56 (2014) 144-153.
- [18] M. Ghovvati, L. Guo, K. Bolouri, N. Kaneko, Advances in Electroconductive Polymers for Biomedical Sector: Structure and Properties, *Mater. Chem. Horizons* 2 (2023) 125-137.
- [19] H. Baniyasi, A. Ramazani S.A, S. Mashayekhan, Fabrication and characterization of conductive chitosan/gelatin-based scaffolds for nerve tissue engineering, *International . Biol. Macromol.* 74 (2015) 360-366.
- [20] G. Street, S. Lindsey, A. Nazzal, K. Wynne, The structure and mechanical properties of polypyrrole, *Mol. Cryst. Liq. Cryst.* 118 (1985) 137-148.
- [21] S. Geetha, C.R. Rao, M. Vijayan, D. Trivedi, Biosensing and drug delivery by polypyrrole, *Anal. Chim. Acta* 568 (2006) 119-125.
- [22] T.P. Kaloni, P.K. Giesbrecht, G. Schreckenbach, M.S. Freund, Polythiophene: From fundamental perspectives to applications, *Chem. Mater.* 29 (2017) 10248-10283.
- [23] G. Gebreyohannes, A. Nyerere, C. Bii, D.B. Sbhathu, Challenges of intervention, treatment, and antibiotic resistance of biofilm-forming microorganisms, *Heliyon* 5 (2019) e02192.
- [24] N.K. Palanisamy, N. Ferina, A.N. Amirulhusni, Z. Mohd-Zain, J. Hussaini, L.J. Ping, R. Durairaj, Antibiofilm properties of chemically synthesized silver nanoparticles found against *Pseudomonas aeruginosa*, *J. Nanobiotechnol.* 12 (2014) 2.
- [25] M.M. Farouk, A. El-Molla, F.A. Salib, Y.A. Soliman, M. Shaalan, The Role of Silver Nanoparticles in a Treatment Approach for Multidrug-Resistant *Salmonella* Species Isolates, *Int. J. Nanomed.* 15 (2020) 6993-7011.
- [26] D.G. Meeker, S.V. Jenkins, E.K. Miller, K.E. Beenken, A.J. Loughran, A. Powless, T.J. Muldoon, E.I. Galanzha, V.P. Zharov, M.S. Smeltzer, J. Chen, Synergistic Photothermal and Antibiotic Killing of Biofilm-Associated *Staphylococcus aureus* Using Targeted Antibiotic-Loaded Gold Nanoconstructs, *ACS Infect. Dis.* 2 (2016) 241-250.
- [27] M. Mishra, S. Kumar, R.K. Majhi, L. Goswami, C. Goswami, H. Mohapatra, Antibacterial Efficacy of Polysaccharide Capped Silver Nanoparticles Is Not Compromised by AcrAB-TolC Efflux Pump, *Front. Microbiol.* 9 (2018).
- [28] B.D. Chithrani, J. Stewart, C. Allen, D.A. Jaffray, Intracellular uptake, transport, and processing of nanostructures in cancer cells, *Nanomedicine: Nanotechnology, Biology Med.* 5 (2009) 118-127.
- [29] G. Sharma, D. Pathania, M. Naushad, N.C. Kothiyal, Fabrication, characterization and antimicrobial activity of polyaniline Th(IV) tungstomolybdophosphate nanocomposite material: Efficient removal of toxic metal ions from water, *Chem. Eng. J.* 251 (2014) 413-421.
- [30] U. Bogdanović, S. Dimitrijević, S.D. Škapin, M. Popović, Z. Rakočević, A. Leskovac, S. Petrović, M. Stoiljković, V. Vodnik, Copper-polyaniline nanocomposite: Role of physicochemical properties on the antimicrobial activity and genotoxicity evaluation, *Mater. Sci. Eng. C* 93 (2018) 49-60.
- [31] V. Mazeiko, A. Kausaite-Minkstiniene, A. Ramanaviciene, Z. Balevicius, A. Ramanavicius, Gold nanoparticle and conducting polymer-polyaniline-based nanocomposites for glucose biosensor design, *Sens. Actuators B Chem.* 189 (2013) 187-193.
- [32] X. Liang, M. Sun, L. Li, R. Qiao, K. Chen, Q. Xiao, F. Xu, Preparation and antibacterial activities of polyaniline/Cu<sub>0.05</sub>Zn<sub>0.95</sub>O nanocomposites, *Dalton Trans.* 41 (2012) 2804-2811.
- [33] E.N. Zare, P. Makvandi, B. Ashtari, F. Rossi, A. Motahari, G. Perale, Progress in Conductive Polyaniline-Based Nanocomposites for Biomedical Applications: A Review, *J. Med. Chem.* 63 (2020) 1-22.
- [34] F. Song, W. Jie, T. Zhang, W. Li, Y. Jiang, L. Wan, W. Liu, X. Li, B. Liu, Room-temperature fabrication of a three-dimensional reduced-graphene oxide/polypyrrole/hydroxyapatite composite scaffold for bone tissue engineering, *RSC Adv.* 6 (2016) 92804-92812.
- [35] M. Cabuk, Y. Alan, M. Yavuz, H.I. Unal, Synthesis, characterization and antimicrobial activity of biodegradable conducting polypyrrole-graft-chitosan copolymer, *Appl. Surf. Sci.* 318 (2014) 168-175.
- [36] N. Maráková, P. Humpolíček, V. Kašpárková, Z. Capáková, L. Martinková, P. Bober, M. Trchová, J. Stejskal, Antimicrobial activity and cytotoxicity of cotton fabric coated with conducting polymers, polyaniline or polypyrrole, and with deposited silver nanoparticles, *Appl. Surf. Sci.* 396 (2017) 169-176.
- [37] N. Salahuddin, A.A. Elbarbary, M.L. Salem, S. Elksass, Antimicrobial and antitumor activities of 1,2,4-triazoles/polypyrrole chitosan core shell nanoparticles, *J. Phys. Org. Chem.* 30 (2017) e3702.
- [38] H.-O. Kim, M. Yeom, J. Kim, A. Kukreja, W. Na, J. Choi, A. Kang, D. Yun, J.-W. Lim, D. Song, S. Haam, Reactive Oxygen Species-Regulating Polymersome as an Antiviral Agent against Influenza Virus, *Small* 13 (2017) 1700818.

- [39] J. Upadhyay, A. Kumar, B. Gogoi, A.K. Buragohain, Biocompatibility and antioxidant activity of polypyrrole nanotubes, *Synth. Met.* 189 (2014) 119-125.
- [40] K. Jomova, M. Valko, Advances in metal-induced oxidative stress and human disease, *Toxicol.* 283 (2011) 65-87.
- [41] F. Ahmadinejad, S. Geir Møller, M. Hashemzadeh-Chaleshtori, G. Bidkhorji, M.-S. Jami, Molecular Mechanisms behind Free Radical Scavengers Function against Oxidative Stress, *Antioxidants* 6 (2017) 51.
- [42] D. Yim, D.-E. Lee, Y. So, C. Choi, W. Son, K. Jang, C.-S. Yang, J.-H. Kim, Sustainable Nanosheet Antioxidants for Sepsis Therapy via Scavenging Intracellular Reactive Oxygen and Nitrogen Species, *ACS Nano* 14 (2020) 10324-10336.
- [43] V. Hasantabar, M. Lakouraj, E. Nazarzadeh Zare, M. Mohseni, Synthesis, Characterization, and Biological Properties of Novel Bioactive Poly(xanthoneamide-triazole-ethersulfone) and Its Multifunctional Nanocomposite with Polyaniline, *Adv. Polym. Technol.* 36 (2015).
- [44] M.R. Gizdavic-Nikolaidis, J.R. Bennett, S. Swift, A.J. Easteal, M. Ambrose, Broad spectrum antimicrobial activity of functionalized polyanilines, *Acta Biomater.* 7 (2011) 4204-4209.
- [45] M. Gizdavic-Nikolaidis, J. Travas-Sejdic, G.A. Bowmaker, R.P. Cooney, C. Thompson, P.A. Kilmartin, The antioxidant activity of conducting polymers in biomedical applications, *Curr. Appl. Phys.* 4 (2004) 347-350.
- [46] B. Bideau, J. Bras, N. Adoui, E. Loranger, C. Daneault, Polypyrrole/nanocellulose composite for food preservation: Barrier and antioxidant characterization, *Food Pack. Shelf Life.* 12 (2017) 1-8.
- [47] A. Naskar, K.-s. Kim, Nanomaterials as Delivery Vehicles and Components of New Strategies to Combat Bacterial Infections: Advantages and Limitations, *Microorganisms* 7 (2019) 356.
- [48] H.A. Alhadlaq, M.J. Akhtar, M. Ahamed, Different cytotoxic and apoptotic responses of MCF-7 and HT1080 cells to MnO<sub>2</sub> nanoparticles are based on similar mode of action, *Toxicol.* 411 (2019) 71-80.
- [49] C. Wan, J. Li, Cellulose aerogels functionalized with polypyrrole and silver nanoparticles: In-situ synthesis, characterization and antibacterial activity, *Carbohydr. Polym.* 146 (2016) 362-367.
- [50] W. Huang, T. Leng, M. Gao, Q. Hu, L. Liu, H. Dou, Scalable dextran-polypyrrole nano-assemblies with photothermal/photoacoustic dual capabilities and enhanced biocompatibility, *Carbohydr. Polym.* 241 (2020) 116224.
- [51] Z. Capáková, K.A. Radaszkiewicz, U. Acharya, T.H. Truong, J. Pacherník, P. Bober, V. Kašpárková, J. Stejskal, J. Pflieger, M. Lehocký, P. Humpolíček, The biocompatibility of polyaniline and polypyrrole, *Mater. Sci. Eng. C.* 113 (2020) 110986.
- [52] J. Stejskal, M. Hajná, V. Kašpárková, P. Humpolíček, A. Zhigunov, M. Trchová, Purification of a conducting polymer, polyaniline, for biomedical applications, *Synth. Met.* 195 (2014) 286-293.
- [53] P. Humpolíček, V. Kasparkova, P. Saha, J. Stejskal, Biocompatibility of polyaniline, *Synth. Met.* 162 (2012) 722-727.
- [54] D.P. Bhattarai, S. Shrestha, B.K. Shrestha, C.H. Park, C.S. Kim, A controlled surface geometry of polyaniline doped titania nanotubes biointerface for accelerating MC3T3-E1 cells growth in bone tissue engineering, *Chem. Eng. J.* 350 (2018) 57-68.
- [55] Y. Arteshi, A. Aghanejad, S. Davaran, Y. Omid, Biocompatible and electroconductive polyaniline-based biomaterials for electrical stimulation, *Eur. Polym. J.* 108 (2018) 150-170.
- [56] P. Bober, B.A. Zasońska, P. Humpolíček, Z. Kuceková, M. Varga, D. Horák, V. Babayan, N. Kazantseva, J. Prokeš, J. Stejskal, Polyaniline–maghemite based dispersion: Electrical, magnetic properties and their cytotoxicity, *Synth. Met.* 214 (2016) 23-29.
- [57] S.M. Bittner, J.L. Guo, A. Melchiorri, A.G. Mikos, Three-dimensional Printing of Multilayered Tissue Engineering Scaffolds, *Mater. Today (Kidlington)* 21 (2018) 861-874.
- [58] S. Vijayavenkataraman, S. Kannan, T. Cao, J.Y.H. Fuh, G. Sriram, W.F. Lu, 3D-Printed PCL/PPy Conductive Scaffolds as Three-Dimensional Porous Nerve Guide Conduits (NGCs) for Peripheral Nerve Injury Repair, *Front. Bioeng. Biotechnol.* 7 (2019).
- [59] B. Ferrigno, R. Bordett, N. Duraisamy, J. Moskow, M.R. Arul, S. Rudraiah, S.P. Nukavarapu, A.T. Vella, S.G. Kumbar, Bioactive polymeric materials and electrical stimulation strategies for musculoskeletal tissue repair and regeneration, *Bioact. Mater.* 5 (2020) 468-485.
- [60] A. Casella, A. Panitch, J.K. Leach, Endogenous Electric Signaling as a Blueprint for Conductive Materials in Tissue Engineering, *Bioelec.* 3 (2021) 27-41.
- [61] M.A. Marsudi, R.T. Ariski, A. Wibowo, G. Cooper, A. Barlian, R. Rachmanty, P. Bartolo, Conductive Polymeric-Based Electroactive Scaffolds for Tissue Engineering Applications: Current Progress and Challenges from Biomaterials and Manufacturing Perspectives, *Int. J. Mol. Sci.* 22 (2021).

- [62] M.D. Ashton, P.A. Cooper, S. Municoy, M.F. Desimone, D. Cheneler, S.D. Shnyder, J.G. Hardy, Controlled Bioactive Delivery Using Degradable Electroactive Polymers, *Biomacromol.* 23 (2022) 3031-3040.
- [63] M. Masoud, M. Mehrnoush, V. Daryoosh, T. Lobat, Electroconductive Nanocomposite Scaffolds: A New Strategy Into Tissue Engineering and Regenerative Medicine, in: E. Farzad (Ed.), *Nanocomposites*, IntechOpen, Rijeka, 2012, p. Ch. 14.
- [64] A.S. Buinov, E.R. Gafarova, E.A. Grebenik, K.N. Bardakova, B.C. Kholkhoev, N.N. Veryasova, P.V. Nikitin, N.V. Kosheleva, B.S. Shavkuta, A.S. Kuryanova, V.F. Burdukovskii, P.S. Timashev, Fabrication of Conductive Tissue Engineering Nanocomposite Films Based on Chitosan and Surfactant-Stabilized Graphene Dispersions, *Polym.* 14 (2022) 3792.
- [65] E. Mostafavi, D. Medina-Cruz, K. Kalantari, A. Taymoori, P. Soltantabar, T.J. Webster, Electroconductive Nanobiomaterials for Tissue Engineering and Regenerative Medicine, *Bioelec.* 2 (2020) 120-149.
- [66] L. Huang, X. Yang, L. Deng, D. Ying, A. Lu, L. Zhang, A. Yu, B. Duan, Biocompatible Chitin Hydrogel Incorporated with PEDOT Nanoparticles for Peripheral Nerve Repair, *ACS Appl. Mater. Interfaces* 13 (2021) 16106-16117.
- [67] B.S. Eftekhari, D. Song, P.A. Janmey, Electrical Stimulation of Human Mesenchymal Stem Cells on Conductive Chitosan-Polyaniline Substrates Promotes Neural Priming, *bioRxiv* (2022) 2022.11.14.516447.
- [68] L. Wang, J. Jiang, W. Hua, A. Darabi, X. Song, C. Song, W. Zhong, M.M. Xing, X. Qiu, Mussel-inspired conductive cryogel as cardiac tissue patch to repair myocardial infarction by migration of conductive nanoparticles, *Adv. Funct. Mater.* 26 (2016) 4293-4305.
- [69] M. Ghovvati, M. Kharaziha, R. Ardehali, N. Annabi, Recent Advances in Designing Electroconductive Biomaterials for Cardiac Tissue Engineering, *Adv. Healthc. Mater.* 11 (2022) 2200055.
- [70] J.G. Hardy, J.Y. Lee, C.E. Schmidt, Biomimetic conducting polymer-based tissue scaffolds, *Curr. Opin. Biotechnol.* 24 (2013) 847-854.
- [71] P. Hazelton, M. Ye, X. Chen, Introduction to Conducting Polymers, *Electrically Conducting Polymers and Their Composites for Tissue Engineering*, ACS 2023, pp. 1-7.
- [72] N. Peidavosi, M. Azami, N. Beheshtizadeh, A. Ramazani Saadatabadi, Piezoelectric conductive electrospun nanocomposite PCL/Polyaniline/Barium Titanate scaffold for tissue engineering applications, *Sci. Rep.* 12 (2022) 20828.
- [73] D.T. Dixon, C.T. Gomillion, 3D-Printed conductive polymeric scaffolds with direct current electrical stimulation for enhanced bone regeneration, *J. Biomed. Mater. Res. B Appl. Biomater.* 111 (2023) 1351-1364.
- [74] N. Fani, M. Hajinasrollah, M. Asghari Vostikolaee, M. Baghaban Eslaminejad, F. Mashhadiabbas, N. Tongas, M. Rasoulianboroujeni, A. Yadegari, K. Ede, M. Tahriri, L. Tayebi, Influence of conductive PEDOT:PSS in a hard tissue scaffold: In vitro and in vivo study, *J. Bioact. Compat. Polym.* 34 (2019) 436-441.
- [75] C.Y. Wu, A.Z. Melaku, F.B. Ilhami, C.W. Chiu, C.C. Cheng, Conductive Supramolecular Polymer Nanocomposites with Tunable Properties to Manipulate Cell Growth and Functions, *Int. J. Mol. Sci.* 23 (2022).
- [76] Z. Feng, K.H. Adolfsson, Y. Xu, H. Fang, M. Hakkarainen, M. Wu, Carbon dot/polymer nanocomposites: From green synthesis to energy, environmental and biomedical applications, *Sustain. Mater. Technol.* 29 (2021) e00304.
- [77] J. Huang, X. Hu, L. Lu, Z. Ye, Q. Zhang, Z. Luo, Electrical regulation of Schwann cells using conductive polypyrrole/chitosan polymers, *J. Biomed. Mater. Res. A* 93 (2010) 164-174.
- [78] A. Escobar, A. Serafin, M.R. Carvalho, M. Culebras, A. Cantarero, A. Beaucamp, R.L. Reis, J.M. Oliveira, M.N. Collins, Electroconductive poly(3,4-ethylenedioxythiophene) (PEDOT) nanoparticle-loaded silk fibroin biocomposite conduits for peripheral nerve regeneration, *Adv. Compos. Hybrid Mater.* 6 (2023) 118.
- [79] L. Wang, Y. Wu, T. Hu, B. Guo, P.X. Ma, Electrospun conductive nanofibrous scaffolds for engineering cardiac tissue and 3D bioactuators, *Acta biomater.* 59 (2017) 68-81.
- [80] T.H. Qazi, R. Rai, D. Dippold, J.E. Roether, D.W. Schubert, E. Rosellini, N. Barbani, A.R. Boccaccini, Development and characterization of novel electrically conductive PANI-PGS composites for cardiac tissue engineering applications, *Acta Biomater.* 10 (2014) 2434-2445.
- [81] Y. Liang, A. Mitriashkin, T.T. Lim, J.C. Goh, Conductive polypyrrole-encapsulated silk fibroin fibers for cardiac tissue engineering, *Biomater.* 276 (2021) 121008.
- [82] B.S. Spearman, A.J. Hodge, J.L. Porter, J.G. Hardy, Z.D. Davis, T. Xu, X. Zhang, C.E. Schmidt, M.C. Hamilton, E.A. Lipke, Conductive interpenetrating networks of polypyrrole and polycaprolactone encourage electrophysiological development of cardiac cells, *Acta biomater.* 28 (2015) 109-120.
- [83] S.Y. Srinivasan, M. Cler, O. Zapata-Arteaga, B. Dörling, M. Campoy-Quiles, E. Martínez, E. Engel, S. Pérez-Amodio, A. Laromaine, Conductive Bacterial Nanocellulose-Polypyrrole Patches Promote Cardiomyocyte Differentiation, *ACS Appl. Bio Mater.* 6 (2023) 2860-2874.

- [84] X. Zhao, P. Li, B. Guo, P.X. Ma, Antibacterial and conductive injectable hydrogels based on quaternized chitosan-graft-polyaniline/oxidized dextran for tissue engineering, *Acta Biomater.* 26 (2015) 236-248.
- [85] M. Mohamadali, S. Irani, M. Soleimani, S. Hosseinzadeh, PANi/PAN copolymer as scaffolds for the muscle cell-like differentiation of mesenchymal stem cells, *Polym. Adv. Technol.* 28 (2017) 1078-1087.
- [86] M.-C. Chen, Y.-C. Sun, Y.-H. Chen, Electrically conductive nanofibers with highly oriented structures and their potential application in skeletal muscle tissue engineering, *Acta Biomater.* 9 (2013) 5562-5572.
- [87] S. Ostrovidov, M. Ebrahimi, H. Bae, H.K. Nguyen, S. Salehi, S.B. Kim, A. Kumatani, T. Matsue, X. Shi, K. Nakajima, Gelatin–polyaniline composite nanofibers enhanced excitation–contraction coupling system maturation in myotubes, *ACS Appl. Mater. Interfaces.* 9 (2017) 42444-42458.
- [88] L. Wang, Y. Wu, B. Guo, P.X. Ma, Nanofiber yarn/hydrogel core–shell scaffolds mimicking native skeletal muscle tissue for guiding 3D myoblast alignment, elongation, and differentiation, *ACS nano* 9 (2015) 9167-9179.
- [89] S. Hosseinzadeh, M. Mahmoudifard, F. Mohamadyar-Toupkanlou, M. Dodel, A. Hajarizadeh, M. Adabi, M. Soleimani, The nanofibrous PAN-PANi scaffold as an efficient substrate for skeletal muscle differentiation using satellite cells, *BioProcess Biosyst. Eng.* 39 (2016) 1163-1172.
- [90] M. Mahmoudifard, M. Soleimani, S. Hatamie, S. Zamanlui, P. Ranjbarvan, M. Vossoughi, S. Hosseinzadeh, The different fate of satellite cells on conductive composite electrospun nanofibers with graphene and graphene oxide nanosheets, *Biomed. Mater.* 11 (2016) 025006.
- [91] F.V. Berti, P. Srisuk, L.P. da Silva, A.P. Marques, R.L. Reis, V.M. Correló, Synthesis and characterization of electroactive gellan gum spongy-like hydrogels for skeletal muscle tissue engineering applications, *Tissue Eng. A* 23 (2017) 968-979.
- [92] M. Sasaki, B.C. Karikkineth, K. Nagamine, H. Kaji, K. Torimitsu, M. Nishizawa, Highly conductive stretchable and biocompatible electrode–hydrogel hybrids for advanced tissue engineering, *Adv. Healthc. Mater.* 3 (2014) 1919-1927.
- [93] K.D. McKeon-Fischer, D.P. Browe, R.M. Olabisi, J.W. Freeman, Poly(3,4-ethylenedioxythiophene) nanoparticle and poly( $\epsilon$ -caprolactone) electrospun scaffold characterization for skeletal muscle regeneration, *J. Biomed. Mater. Res. A* 103 (2015) 3633-3641.
- [94] A. Wibowo, C. Vyas, G. Cooper, F. Qulub, R. Suratman, A.I. Mahyuddin, T. Dirgantara, P. Bartolo, 3D Printing of Polycaprolactone–Polyaniline Electroactive Scaffolds for Bone Tissue Engineering, *Mater.* 13 (2020) 512.
- [95] A.I. Rezk, D.P. Bhattarai, J. Park, C.H. Park, C.S. Kim, Polyaniline-coated titanium oxide nanoparticles and simvastatin-loaded poly( $\epsilon$ -caprolactone) composite nanofibers scaffold for bone tissue regeneration application, *Colloids Surf. B Biointerfaces* 192 (2020) 111007.
- [96] F. Ghorbani, B. Ghalandari, A.L. Khan, D. Li, A. Zamanian, B. Yu, Decoration of electrical conductive polyurethane-polyaniline/polyvinyl alcohol matrixes with mussel-inspired polydopamine for bone tissue engineering, *Biotechnol. Prog.* 36 (2020) e3043.
- [97] P. Li, S. Zhang, K. Li, J. Wang, M. Liu, X. Gu, Y. Fan, The promoting effect on pre-osteoblast growth under electrical and magnetic double stimulation based on PEDOT/Fe<sub>3</sub>O<sub>4</sub>/PLGA magnetic-conductive bi-functional scaffolds, *J. Mater. Chem. B* 6 (2018) 4952-4962.
- [98] B. Maharjan, V.K. Kaliannagounder, S.R. Jang, G.P. Awasthi, D.P. Bhattarai, G. Choukrani, C.H. Park, C.S. Kim, In-situ polymerized polypyrrole nanoparticles immobilized poly( $\epsilon$ -caprolactone) electrospun conductive scaffolds for bone tissue engineering, *Mater. Sci. Eng. C* 114 (2020) 111056.